

**ARMOURJOINT ADJUSTABLE**

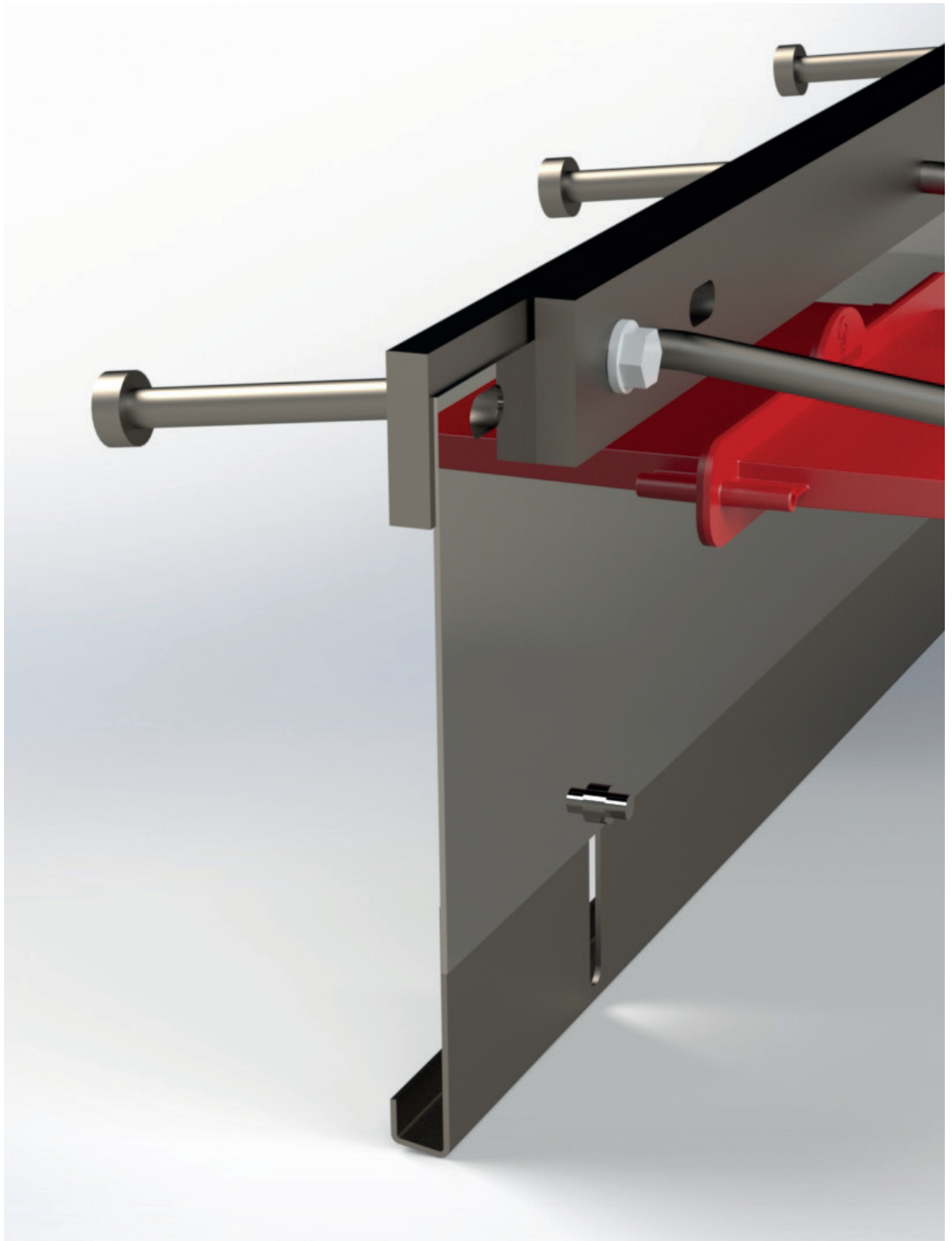

[www.isedio.com](http://www.isedio.com)

Iседio Limited. Unit 10 Jubilee Park, Badger's Cross Lane, Somerton, TA11 7JF, UK.  
T: +44 (0) 1458 270 600 | E: [info@isedio.com](mailto:info@isedio.com) | Registered in England and Wales: 07025519

Copyright © 2018 Iседio Limited. Errors and missions excepted. Iседio Limited reserves the right to revise this documentation and to make changes in content from time to time without obligation on the part of Iседio Limited to provide notification of such revision or change. Information contained within this document is approximate.

### PRODUCT DESCRIPTION & USES

ARMOURJOINT ADJUSTABLE is a leave-in-place formwork, load transfer and edge protection joint system suitable for heavy duty industrial concrete floors.

The joint system comprises two top strips, an upper divider plate, a lower divider plate, load transfer plate dowels and sleeves. The lower divider plate is attached to the upper divider plate by a special fastener that requires no tools for adjustment. This innovation is protected by a patent. The joint is designed such that once cast in-situ, as the two slab panels either side of the joint begin to cure and shrink, the joint separates such that one slab panel has the sleeve and top strip and the other has the top strip, divider plate and dowel. The dowel bridges across the joint and is embedded in both slab panels.

Formwork for casting a concrete slab is achieved by the vertical divider plates which supports the top strip edge protection and load transfer plate dowels.

Slab arris protection is provided by way of cold drawn steel top strips with shear studs that anchor the top strips in the concrete.

Load transfer across the joint is achieved by assymmetric plate dowels and sleeves. The plate dowels are attached to the vertical divider plate and the sleeves are held in place under friction and are detachable as the joint opens up. Intersections for corners, tees and 4 ways are available.

### MATERIAL SPECIFICATION

COMPONENT	MATERIAL
TOP STRIPS	COLD DRAWN STEEL TO BS EN 10277-2:2008 (CAN BE SUPPLIED IN STAINLESS STEEL OR HOT DIP GALVANISED)
FRANGIBLE FASTENER	NYLON
DIVIDER PLATE	STEEL DC01 TO BS EN 10130:2006
LOAD TRANSFER DOWEL PLATE	8MM & 12MM - S355 STEEL TO BS EN 10025-2:2004
SLEEVE	8MM & 12MM - PP

### TECHNICAL DATA

DESCRIPTION	DIMENSION & TOLERANCE
JOINT LENGTH	3000MM +/-2.0MM
STRAIGHTNESS	+/-0.5MM IN 600MM
GENERAL DIMENSIONAL TOLERANCE	DIMENSIONS < 12MM +/-0.5MM DIMENSIONS > 12MM +/-2.0MM

Information on load transfer capacities can be found on the Load Transfer Capacity Datasheet.

### PLAN AND END IMAGES

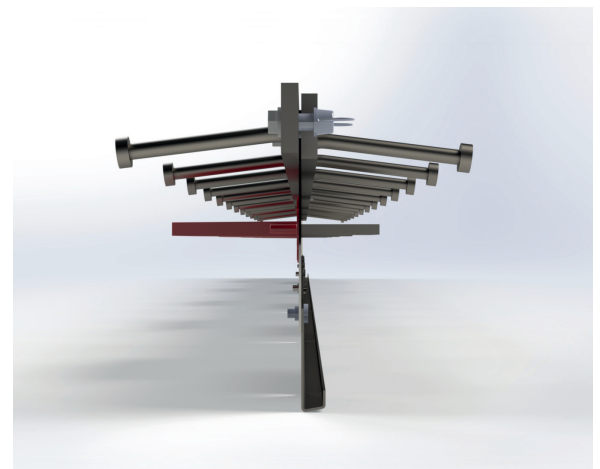
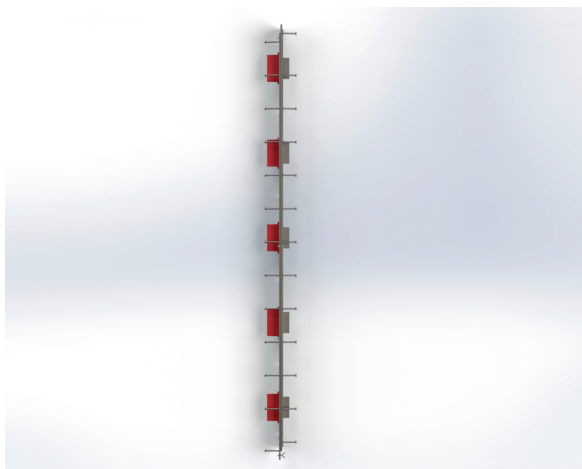

PACKAGING INFORMATION

5 X 8MM DOWELS (600MM CENTRES)

JOINT (MM)	QTY & METRES OF JOINT PER BUNDLE	APPROX BUNDLE WEIGHT INC PACKAGING (KG)	MAX NO OF BUNDLES & METRES PER TRUCK
100-130MM	50 OFF - 150M	1746 KG	13 BUNDLES - 1950M
130-150MM	49 OFF - 147M	1780 KG	13 BUNDLES - 1911M
150-200MM	49 OFF - 147M	1815 KG	13 BUNDLES - 1911M
200-250MM	42 OFF - 126M	1646 KG	14 BUNDLES - 1764M
250-300MM	35 OFF - 105M	1559 KG	15 BUNDLES - 1575M

5 X 12MM DOWELS (600MM CENTRES)

JOINT (MM)	QTY & METRES OF JOINT PER BUNDLE	APPROX BUNDLE WEIGHT INC PACKAGING (KG)	MAX NO OF BUNDLES & METRES PER TRUCK
100-130MM	40 OFF - 120M	1548 KG	15 BUNDLES - 1800M
130-150MM	42 OFF - 126M	1681 KG	14 BUNDLES - 1764M
150-200MM	42 OFF - 126M	1719 KG	13 BUNDLES - 1638M
200-250MM	42 OFF - 126M	1793 KG	13 BUNDLES - 1638M
250-300MM	35 OFF - 105M	1672 KG	14 BUNDLES - 1470M